

# ACS Acoustic Wall Tie

- ✓ **Noise & Vibration Attenuation**
- ✓ **BS EN 845 Tested**
- ✓ **50 – 300mm Cavities**
- ✓ **Grade 304 Stainless Steel**
- ✓ **Natural Rubber Blocks**

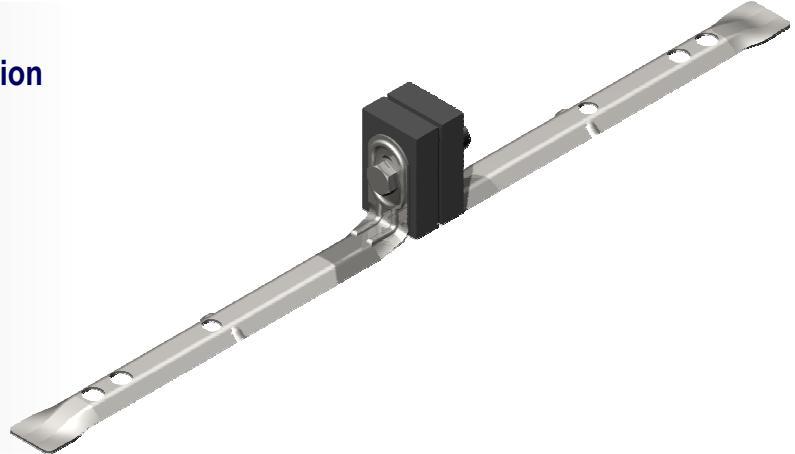

## Design Features

The ACS Acoustic brickwork ties are designed to provide structural stability whilst attenuating noise and vibration between cavity walls.

The ties, fixings and washers are manufactured from Grade 304 stainless steel to provide high levels of corrosion resistance. The natural rubber acoustic blocks are designed to ensure no metallic contact occurs between external and internal brickwork or internal partitions reducing the passage of noise and vibration.

The ties have been tested in line with the requirements of BS EN 845 and provide a declared load capacity of 0.75kN in tension, compression and shear. The ties unique design is complete with in-built drip features and safety ends for embedment into the mortar joint.

The acoustic ties are available in a range of lengths to suit cavities from 50-300mm and configurations to suit fixing back to various structures

## Typical Applications

- Multiplex cinemas.
- Sound and recording studios.
- Hearing test rooms.
- Nightclubs.

For further information or technical assistance please contact the ACS Technical Department on 0844 850 0860 or email [technical@acsstainless.co.uk](mailto:technical@acsstainless.co.uk)

**LEEDS**  
Cross Green Approach  
Cross Green Industrial Park  
Leeds LS9 0SG  
Tel: +44 (0)113 391 8200  
Fax: +44 (0)113 391 8209

**LONDON**  
Crown House  
Home Gardens  
Dartford  
Tel: +44 (0)1322 424 510  
Fax: +44 (0)1322 424 504

**GLASGOW**  
Festival House  
150 Brand Street  
Glasgow G51 1DH  
Tel: +44 (0)141 314 0048  
Fax: +44 (0)141 314 0026

