

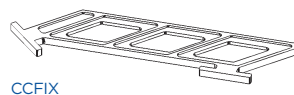

Thermo-loc plus X cavity closers

Higher insulation closers for eliminating damp and 'cold bridging' around doors, windows and sills

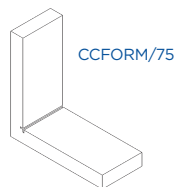
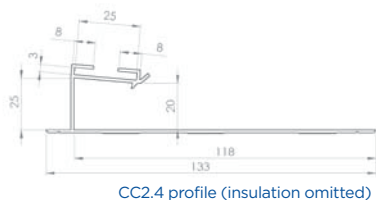

Use

- To close the cavity at external doors, window jambs and sills
- To provide thermal insulation and prevent 'cold bridging'
- To provide a DPC at external doors, window jambs or sills
- To provide higher insulation properties than standard polystyrene

Features and benefits

- Provides an effective DPC and thermal barrier between frame, inner and outer wall leaf
- Thermal conductivity of 0.028W/mK
- Exceeds the minimum thermal resistance path of 0.45m²K/W stipulated in Robust Details 'limited thermal bridging and air leakage'
- Rigid profile extrusion allows both first and second fix
- Components available to make up 'on-site' frame formers
- Suitable for all frame and sill positions (see fig.1)
- Durable and resistant to decay
- Insulation option to suit your requirements both thermal and fire rated
- Simple on-site trimming to cope with 'rogue' cavity widths
- Better insulation properties than standard Polystyrene
- Global warming potential of 1
- Ozone depletion potential of zero

Quality

- BBA Approved
- Satisfies NHBC Standards
- Manufactured to BS EN ISO 9001 and IS BN ISO 14001
- Complies with Building Regulation Approved Documents C (2004 edition), L1 & L2 (2013 editions)
- Complies with Robust Details 'limited thermal bridging and air leakage'
- Satisfies BRE document 'Thermal insulation: avoiding risks'
- Meets all relevant British Standards

Material and colour choice

- Rigid profile extruded in white UPVC
- Supplied in 2.4 metre lengths
- Standard cavity options available 50mm - 150mm
- Extruded Polystyrene insulation 0.028W/mk
- Wider cavities available to special order

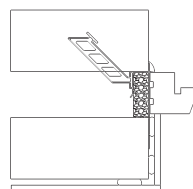

Flush jamb

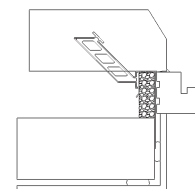

Fully rebated (check reveal)

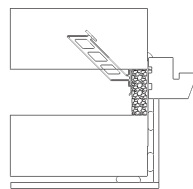

Staggered jamb

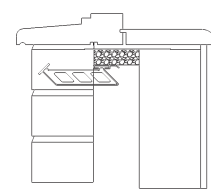

Sill detail

Fig.1

Installation advice

- Can be used in both first and second fix applications
- Cut the cavity closer into required lengths allowing the jamb section to overlap the sill section and to butt the underside of the lintel
- In first fix application the cavity closer should be nailed to the jamb/sill of the door or window frame and the whole assembly built in as work proceeds. Alternatively the closer can be built in sections using fixing ties as work proceeds or pre built to act as an opening former by using a timber brace (fig.2a) and corner forms (fig.2b)
- For second fix applications, the cavity closer is pushed into the open cavity after building work is complete. The compressible nature of the exposed insulation material is used to create a friction fit in the cavity, or alternatively the insulation can be trimmed to fit using a sharp knife
- Joining 'off cut' sections should be kept to a minimum and not carried out to sill sections. Sections are joined by mitre cutting the closer profile to allow the downward cut to run away from the jamb. Insulation should be extended from the lower closer profile to allow this to slot into the upper profile to maintain a rigid section. All overlaps to be tape sealed



Thermo-loc plus X cavity closers

Higher insulation closers for eliminating damp and 'cold bridging' around doors, windows and sills

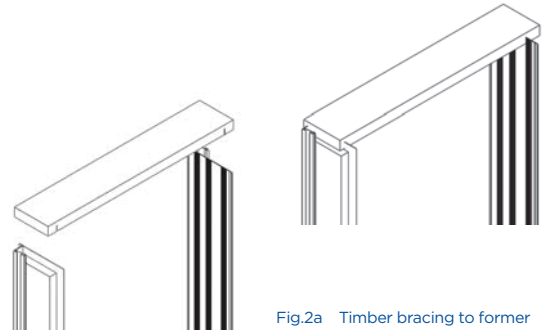

Fig.2a Timber bracing to former

Page 2 of 2

How to order

- Establish the cavity width and select the correct cavity closer width, or the next size up to ensure the cavity can be closed
- In jamb and sill applications, first estimate the total length of cavity closer required, then order the correct number of individual 2.4 metre lengths so no joint pieces
- To use as window formers allow two CCFORM's per opening to support closer in lower corners
- Fixing ties are available for secure fixing if required (particular attention around door openings). Allow for ties fitted at 450mm centres

Bill of quantity

NBSPlus

F30 Accessories/sundry items for brick/block/stone walling

Clause

180 CAVITY CLOSURES FOR CLOSING AROUND WINDOW & DOOR OPENINGS

To extend not less than 150mm beyond ends of lintels/bridgings.

• Manufacturer: **Timloc Building Products, Rawcliffe Road, Goole,**

East Yorkshire, DN14 6UG. Tel: 01405 765567,

Fax: 01405 720479. Web: www.timloc.co.uk

• Reference:.....eg. CC2.4 XPS/75 (Thermo-loc Cavity Closer, Extruded Polystyrene, 2.4m, 75mm cavity)

• Accessories: Fixing ties available, 6 No. per 2.4m cavity closer & corner forms for making opening formers. Jointing tape available.

Product codes

Thermo-loc plus X and plus C cavity closers

Description	Cavity width	Length	Pack	Product code
Thermo-loc plus X	50mm	2.4m	5	CC2.4 XPS/50
Thermo-loc plus X	75mm	2.4m	5	CC2.4 XPS/75
Thermo-loc plus X	90mm	2.4m	5	CC2.4 XPS/90
Thermo-loc plus X	100mm	2.4m	5	CC2.4 XPS/100
Thermo-loc plus X	125mm	2.4m	5	CC2.4 XPS/125
Thermo-loc plus X	150mm	2.4m	5	CC2.4 XPS/150
Thermo-loc corner form	50mm	175mm	2	CCFORM/50
Thermo-loc corner form	75mm	175mm	2	CCFORM/75
Thermo-loc corner form	90mm	175mm	2	CCFORM/90
Thermo-loc corner form	100mm	175mm	2	CCFORM/100
Fixing tie	-	-	30	CCFIX

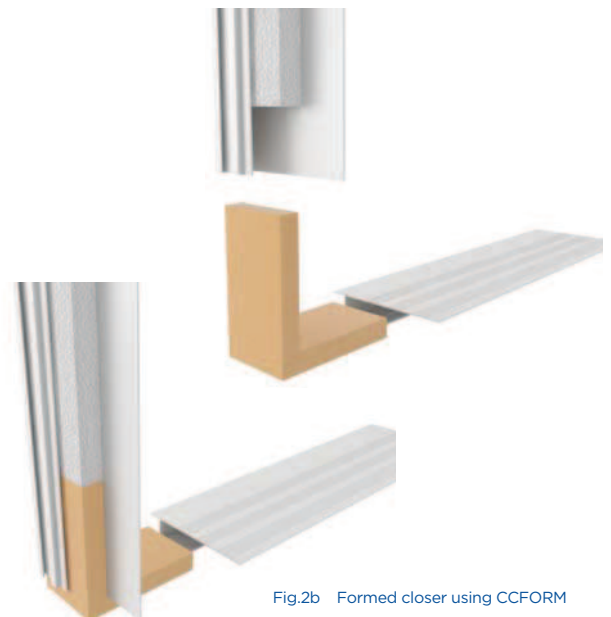

Fig.2b Formed closer using CCFORM



Fig.3

Insulation options

Extruded Polystyrene (plus X)

Thermal conductivity

0.028W/mK

Technical considerations

- BRE Document 'Thermal insulation: avoiding risks' and Robust Details stipulate: "When a window or door frame is set back behind the inner face of a dense outer masonry leaf, it should overlap an insulated closer by a minimum of 30mm for BRE exposure zones Sheltered to Severe; but fully rebated (check reveals) for zones Very Severe" (see fig.3)
- With reference to insulation, the products in this range do not use, contain or produce Urea Formaldehyde, CFC's or indeed any of the so called soft CFC's, ie. HCFC's & HFA's. They have an ozone depletion potential of zero and global warming potential of 1